

FORTRESS HEAVY DUTY CANTILEVER SLIDE GATE

BY TYMETAL CORP.

The Fortress Heavy Duty Slide Gate, manufactured by Tymetal Corp., is a cantilever system consisting of single or multiple panels. Appropriate for openings up to 30 feet for single gates and up to 60 feet for doubles, the Fortress Gate is designed to provide rigidity and stability.

The frame is fabricated from aluminum alloy extrusions with primary members (top and bottom) rectangular in shape with a cross section not less than 2" x 5". Vertical members at the ends of the frame have a cross section of no less than 2" x 2". Intermediate vertical members are 1" x 2" in cross section.

The frame is supported from the track of extruded aluminum alloy by two self-aligning, 4-wheeled, sealed lubricant, ball bearing truck assemblies. Tymetal cantilever slide gates lead the industry in quality of materials and design, with over 25 years of continuous duty use throughout North America. All Tymetal slide gates include the following features for reliability and end user safety:

1. Tymetal trucks are designed for slide gate use and are tested in extreme load and weather conditions
2. Tymetal gates are built to ASTM F2200 and ASTM F1184 (Type 2 Class 2)
3. Tymetal gates are supplied with gap protectors and guide roller covers
4. Tymetal gates are designed and built to order - matching your specific project needs
5. See the Tymetal design details on the back of this page

- ◆ Automated Gates
- ◆ Cedar
- ◆ Chain Link
- ◆ Guard Rail
- ◆ Maximum Security
- ◆ Alum & Steel Ornamental
- ◆ Vinyl Systems
- ◆ Wire Partitions
- ◆ _____ and More



Ed@unitedfence.com
 Call/Text 781-985-4078
 Fax 781.826.9654



Tymetal Corp.

(800) 328-GATE (4283) • www.tymetal.com
 Greenwich, NY • Pearland, TX



CRITICAL DIMENSION CHART

MARK	DESCRIPTION	FORMULA	DIM.
A	CLEAR OPENING	A	-
B	COUNTERBALANCE POST SPACING C/C	(A/2)-11"	-
C	OVERALL GATE LENGTH	A x 1.5	-
D	COUNTERBALANCE LENGTH	A x 0.5	-
E	NOMINAL GATE HEIGHT	E	-
F	POST HEIGHT (W BARB ARMS)	E + 1'-6"	-
G	FABRIC HEIGHT	E - 1'-0"	-

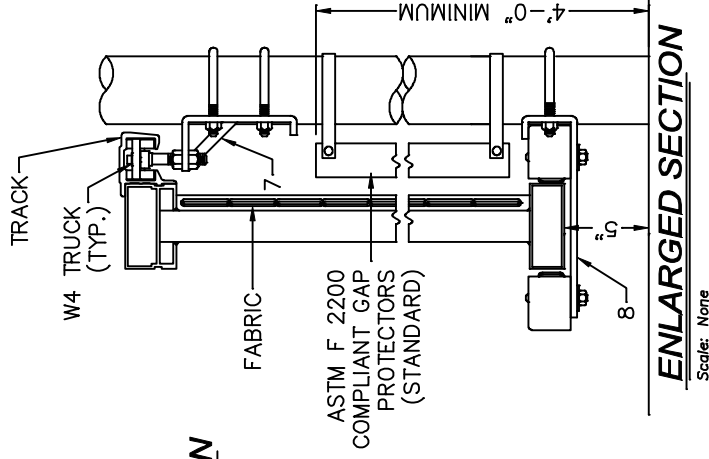
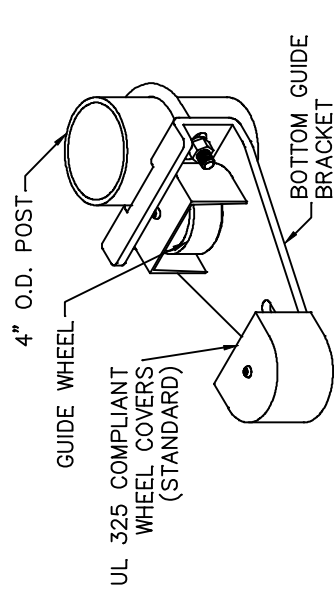
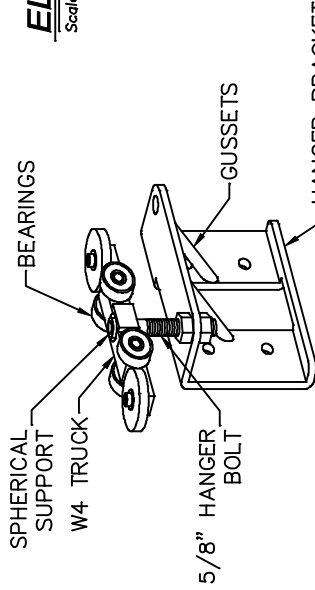
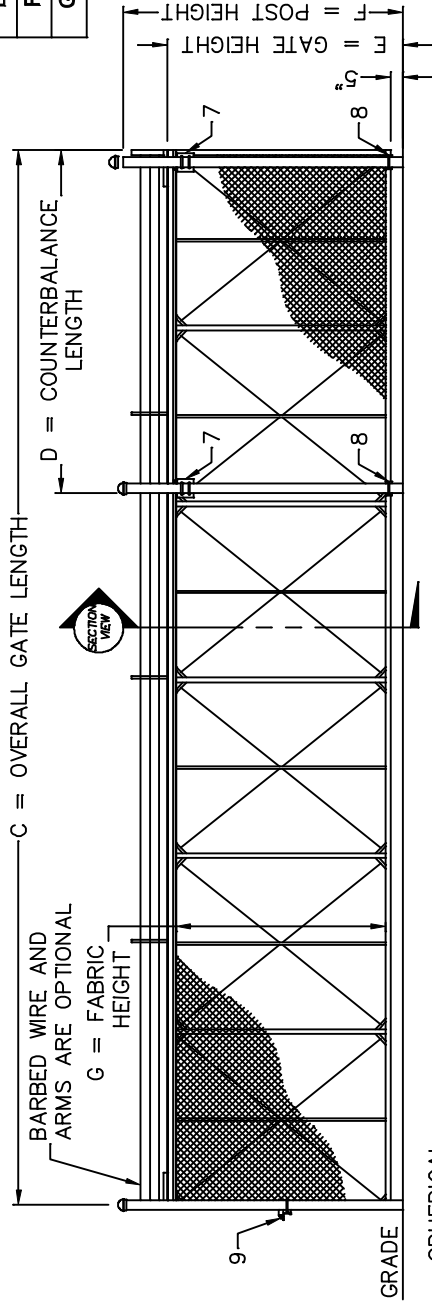
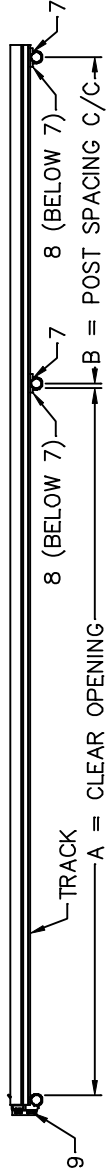

- NOTES:
- ALL FITTINGS STANDARDLY PROVIDED FOR 4" O.D. POSTS. OTHER SIZES AVAILABLE UPON REQUEST.
 - BARB ARMS (FOR BARBED WIRE) OPTIONAL.

Tymetal Corp.
www.tymetal.com

2549 STATE ROUTE 40
GREENWICH, N.Y. 12834
PH:(800) 328-4285 - FX(516) 692-9404

8 BOTTOM GUIDE

9 CATCH ASSEMBLY

10 ENLARGED SECTION

HEAVY DUTY CANTILEVER SLIDE GATE